

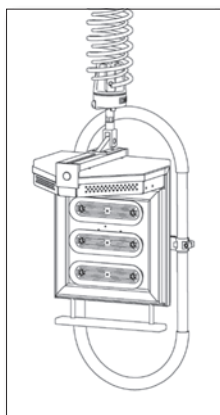

SmartLifter DETAILS

Composition: Aluminum w/ anodized finish
 Rotation: 360°
 Mounting: Mast-mounted to BigFoot™ portable base, underhung from monorail
 Reach: Boom length up to 12 ft.

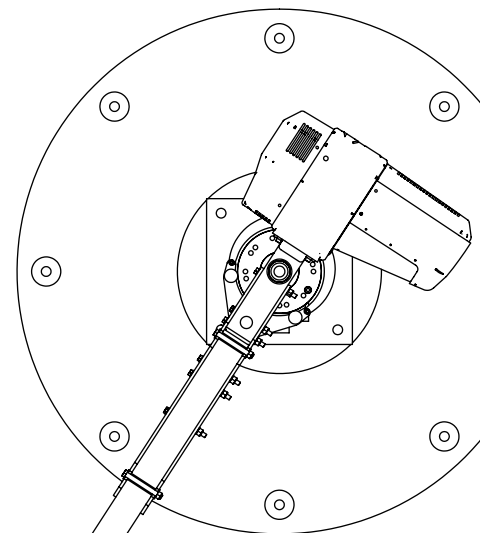
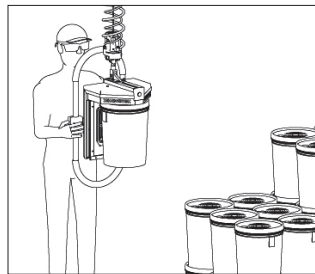
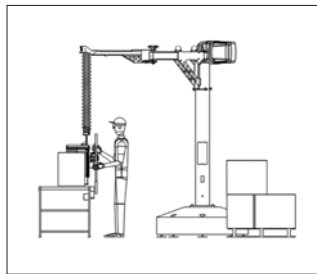
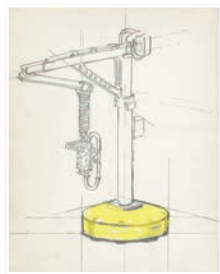

SmartLifter™ is PATENTED

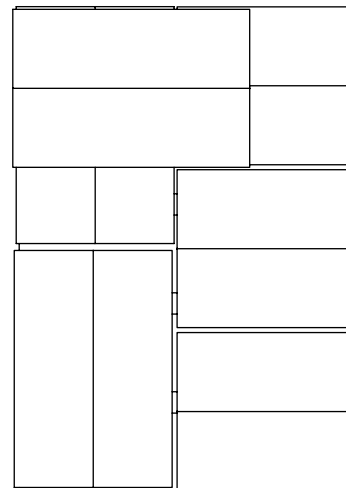
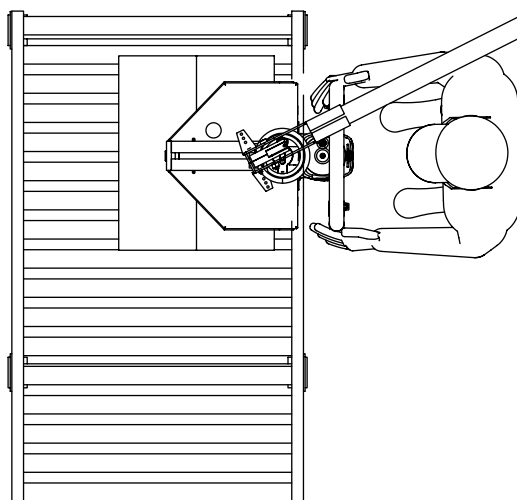

SmartLifter

ERGONOMIC LIFT

Automated vacuum carton picker grips, balances, and stacks cartons with fingertip pressure. Attached to Gorbel® EasyArm® G-Force®.



SmartLifter™ is PATENTED

- ERGONOMICS:**
 - Ergonomic padded handle gives operator freedom of position, visibility, and comfort
 - Force-sensing hub is variable-speed controlled and intuits operator intention
 - In neutral position, handle allows operator to place carton or pail directly on pallet without bending
 - Quick-release levers allow for handle adjustment so items can be placed on tall stacks without strain
 - Operators have completely free range of motion and fingertip control
- OPERATION:**
 - Versatile for all configurations of cartons; special version available for lifting pails
 - Exclusive SmartBalance technology adjusts automatically to rebalance the load
 - Designed to eliminate tangling, allow for infinite rotation
 - Vacuum grip engages automatically when carton is detected, releases when it senses the carton has been set down
 - Adjustable carton support allows for an array of box heights; quick-release clamps lock stop in place when desired
 - Grips from the side, allowing for snugly-packed pallets and eliminating product loss due to carton-top seal failures
 - Hangs balanced when empty
- MAINTENANCE:**
 - Oil-less design ensures cleanliness; virtually maintenance-free
 - Lubricated-for-life air cylinder requires no oiling
 - Venturi-style pumps have no moving parts, require no lubrication
 - Vacuum filters, the only maintenance-replaceable item, are easily changed via access panel