

**MAXIMIZE
WAREHOUSE
SPACE** **MINIMIZE COSTS**

FlexTrak



Engineered Products



**THINK
OUTSIDE THE
LANE**

At Engineered Products, we're focused on one thing—maximizing space. We've provided material handling and storage solutions to warehouses just like yours for over half a century. And while our solutions maximize space and operational capabilities, they also minimize costs. Every inch and every dime is optimized at Engineered Products.

Bring a new level of flexibility to your warehouse with Engineered Product's new FlexTrak carton flow system. Designed for warehouse environments where re-slotting occurs frequently, FlexTrak eliminates the need for restrictive slotting lanes, allowing products of any size to be easily moved from one area to the next.

FlexTrak Bed Carton Flow Features:

- Installs in new or existing rack applications
- Drop-in design allows for easy addition to existing shelving without the use of tools
- Laneless design accommodates changing product, tote, and carton dimensions allowing products to be placed in any carton flow bed location without lane reconfiguration.
- Carton flow hangers act as a front stop
- Full flow bed of rollers provides flexible carton flow support and consistent carton flow
- Great for use in: Seasonal Products, Dynamic Slotting, e-commerce, High SKU turnover



In-House Engineering

Having professional engineers on-site means we're armed and ready to meet any and all storage challenges. Need more space for production? Need to break pallets for faster picking? Or perhaps you need a redesign to accommodate a product addition. Whatever the case, our engineers know storage and racking inside and out, and have the expertise to make it happen.

Individualized Design

No two problems are the same, therefore neither are any two storage solutions. We make sure we understand not only your challenges, constraints and business goals in relation to your storage facility, but how your material handling system fits into your operation as a whole. From there we create a truly customized storage solution to perfectly fit your unique needs.

Unrivaled Support Team

You'll never feel lost or out of the loop when you partner with Engineered Products. Our top-notch team of product, engineering and installation experts will make sure you know and understand exactly what's happening every step of the way; and our customer service team is always on hand to answer any questions.

Physical Specs

- FlexTrak is manufactured in 12" or 15" bf widths
- FlexTrak supports 40 psf with unsupported lengths up to 8'-0"
- Product guides are not required but snap on entry separators are available upon request (no hardware required)
- Pitch requirement based on product weight and type of packaging
- Heavier or smaller products may require roller assemblies on 2" centers

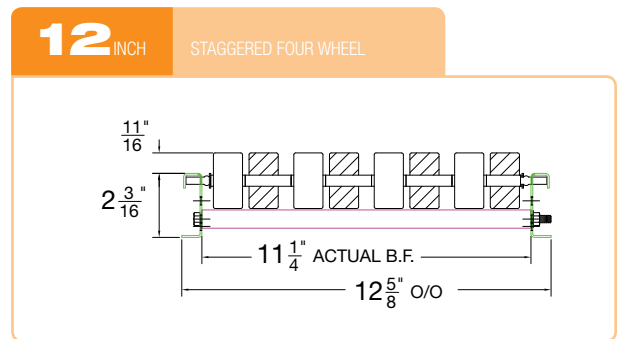
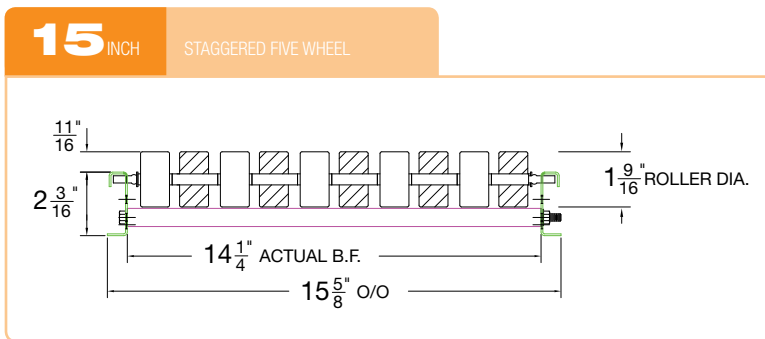

- FlexTrak lanes are available in 12" or 15" widths.
- Actual bf of 12.625" and 15.625"
- Wheel assemblies are available in 2" or 3" centers.

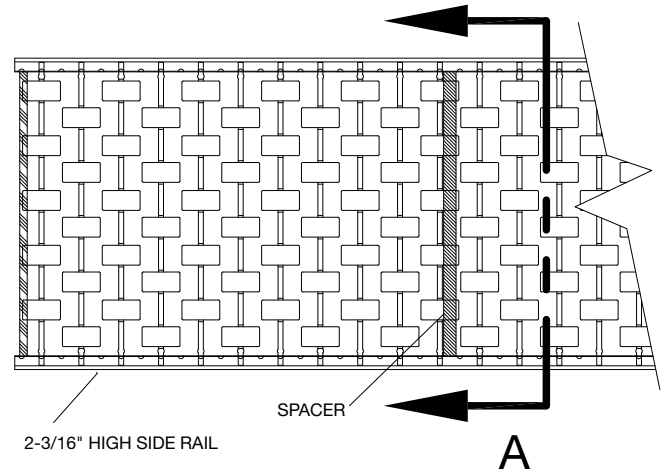
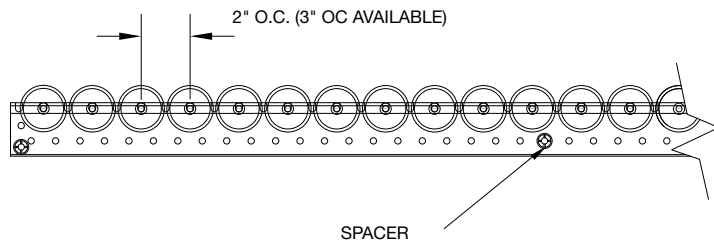

Lane Capacities

Speed and precision play a pivotal role in warehouse and distribution center operations. Proper product flow is essential to improving supply chain efficiency and keeping your workers' stress and strain to a minimum. Knowing your lane capacity allows proper configuration and maximum productivity, with your product flowing the pick points right on time.

7'-6" 60 LBS PER SQUARE FOOT	8'-0" 50 LBS PER SQUARE FOOT	8'-6" 40 LBS PER SQUARE FOOT	9'-0" 30 LBS PER SQUARE FOOT	9'-6" 25 LBS PER SQUARE FOOT	10'-0" 20 LBS PER SQUARE FOOT
---	---	---	---	---	--

FlexTrak lanes over 10' 0" in length require an intermediate support beam. Please note that the longest span will dictate the lane capacity.

Applications

Focus more on your customers and less on your products with the fluidity offered by FlexTrak. Change configurations to flow with your needs with seasonal products, dynamic slotting, e-commerce or high-turnover SKU applications. Our experts will help you optimize performance and productivity for maximum profit.



Options

Our first step is to understand your inventory requirements. Are your carton sizes consistent or do they vary by SKU? Do SKUs, carton types and sizes change frequently? Is system re-slotting a concern? With these answers, choosing your options is a snap.

KNUCKLE DOWN



IMPACT PLATE

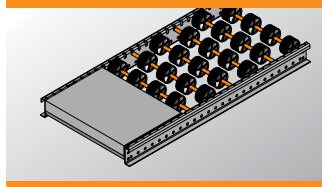

ENTRY GUIDE



Design Your Solution

We help many different industries determine what kind of storage equipment is ideal for their product mix and operational needs. Obviously, there are a whole host of options from the simple to the complex.

We will help you determine the best mix to keep your business booming by noticing the elephant in the room. Evaluation of the height of your shelf openings in flow rack is a good place to start. If some cases are taller than others, it causes difficulty for pickers reaching into them. In the meantime, lower profile cartons have copious amounts of wasted space between them and the next level. To maximize your system's capacity, consider grouping cartons of similar sizes together, or regularly reconfiguring your carton flow beam spacing to fit the current inventory profile.

FLEXTrak LANE WIDTH

Beam Length (Clear)	96"	100"	102"	108"	120"	144"
12" Lanes	0	4	3	1	3	0
15" Lanes	6	3	4	6	5	9
Total Beam Utilization	93.75	97.375	100.375	106.375	116	140.625

FlexTrak is manufactured in two different widths to make continuous wheel supports across one bay of rack. By utilizing as many 15" bf lanes as possible and filling in with 12" bf lanes Engineered Products can optimize your lane capacities.

FLEXTrak ROLLER CENTERS

Carton Length	7"	10"	> 10"
Wheel Assembly Centers	2"	3"	3"

Wheel Assemblies are available in 2" or 3" centers.

Please note that roller spacing is dependent upon carton size, material stiffness, environmental conditions (e.g., room humidity, temperature, etc.)

FLEXTrak HANGERS

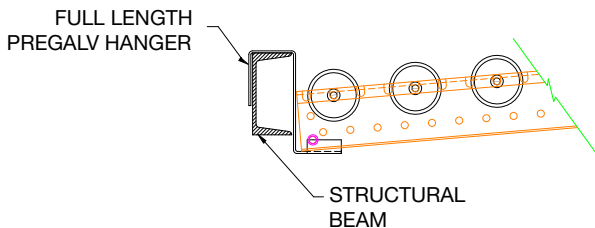
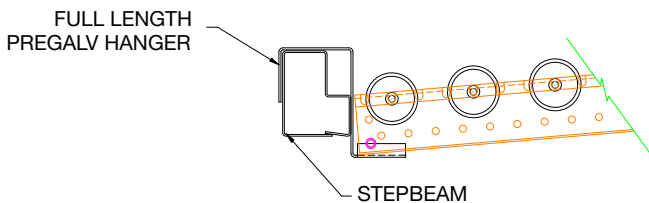

Think outside the lane.

Bring a new level of flexibility to your warehouse with Engineered Product's new FlexTrak carton flow system. Designed for warehouse environments where re-slotting occurs frequently, FlexTrak eliminates the need for restrictive slotting lanes, allowing products of any size to be easily moved from one area to the next.



Engineered Products

355 Woodruff Road, Suite 204 | Greenville, SC 29607 | (864) 234-4888 | www.engprod.com