

DEFINING RUGGED

NEW

EXCEPTIONAL ENGINEERING | ROCK SOLID | EXTENSIVE TESTING



FORKLIFT MOUNT: SINGLE LIGHT BRACKET WITH CLAM SHELL

Placement	Tilt	Weight	Height	Width	Depth
Attaches directly to the top of the overhead guard	Yes - up to 160°	5.50 lbs.	8.87"	6.40"	6.41"

Features:

- Heavy gauge steel construction for long-term durability in a rugged environment
- Black powdercoat finish for maximum corrosion resistance
- The light bracket attaches to the overhead guard and allows a single light to be mounted in multiple orientations
- The bracket can be used with overhead guard supports that are 2" to 5" wide
- The bracket provides for 4.75" of travel up and down
- The Clam Shell provides articulation that allows lights to be mounted in locations where the mounting surface is at an angle

Item No. **7160-0608**

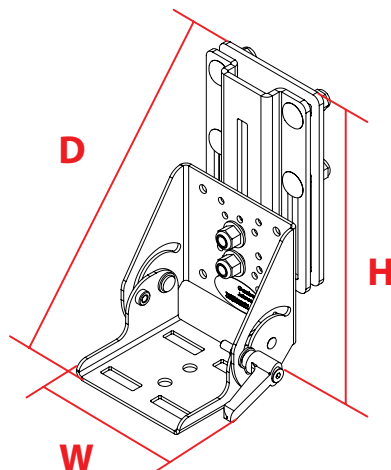

**GAMBER
JOHNSON**

Very Well Connected™

3001 Borham Ave. | Stevens Point, WI 54481, USA
Phone: 715.344.3482 | Toll-free: 800.487.9220 | Fax: 715.344.5209
Email: gamberj@gamberjohnson.com | Website: www.gamberjohnson.com

Follow us on:   

This document, including images, may not be reproduced partly or fully without the expressed written consent of Gamber-Johnson's Marketing Department.
© Copyright 2015 Gamber-Johnson LLC