

# DEFINING RUGGED

NEW

EXCEPTIONAL ENGINEERING | ROCK SOLID | EXTENSIVE TESTING



## FORKLIFT MOUNT: DUAL LIGHT BRACKET WITH CLAM SHELL AND PLATE

Placement	Tilt	Swivel	Weight	Height	Width	Depth
Attaches directly to the top of the overhead guard	Yes - up to 160°	Clam Shell - 360°	8.10 lbs.	9.39"	10.0"	7.41"

### Features:

- Heavy gauge steel construction for long-term durability in a rugged environment
- Black powdercoat finish for maximum corrosion resistance
- The light bracket attaches to the overhead guard and allows up to two lights to be mounted in multiple orientations
- The bracket can be used with overhead guard supports that are 2" to 5" wide
- The bracket provides for 4.75" of travel up and down
- There are two (2) three inch slots to accommodate lights with hardware up to 3/8"
- The Clam Shell provides articulation that allows lights to be mounted in locations where the mounting surface is at an angle
- The large plate will accommodate a variety of lighting options (Blue/Red Safety Lights, Amber Flashing Lights, etc.)

Item No. **7160-0609**

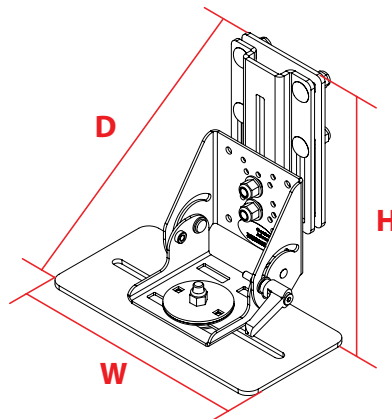

**GAMBER  
JOHNSON**

Very Well Connected™

3001 Borham Ave. | Stevens Point, WI 54481, USA  
Phone: 715.344.3482 | Toll-free: 800.487.9220 | Fax: 715.344.5209  
Email: [gamberj@gamberjohnson.com](mailto:gamberj@gamberjohnson.com) | Website: [www.gamberjohnson.com](http://www.gamberjohnson.com)

Follow us on:



This document, including images, may not be reproduced partly or fully without the expressed written consent of Gamber-Johnson's Marketing Department.  
© Copyright 2015 Gamber-Johnson LLC